

## EAB-80

# Instruction Manual for Cold Storage Alarm



### Safety Rules

Danger:

- Strictly distinguish the sensor leads, power cords, and output relay interfaces. Do not make incorrect connections, and the relays should not be overloaded.
- All wiring changes must be made with the power disconnected.

Warning:

This controller is prohibited from being used in water or excessively humid environments, as well as in high - temperature, strong electromagnetic interference, and highly corrosive environments.

Notice:

- The supply voltage should match the voltage marked on the controller, and the stability of the supply voltage should be ensured.
- To avoid potential interference, it is recommended to keep an appropriate distance between the sensor leads and the power cords.

### Product size

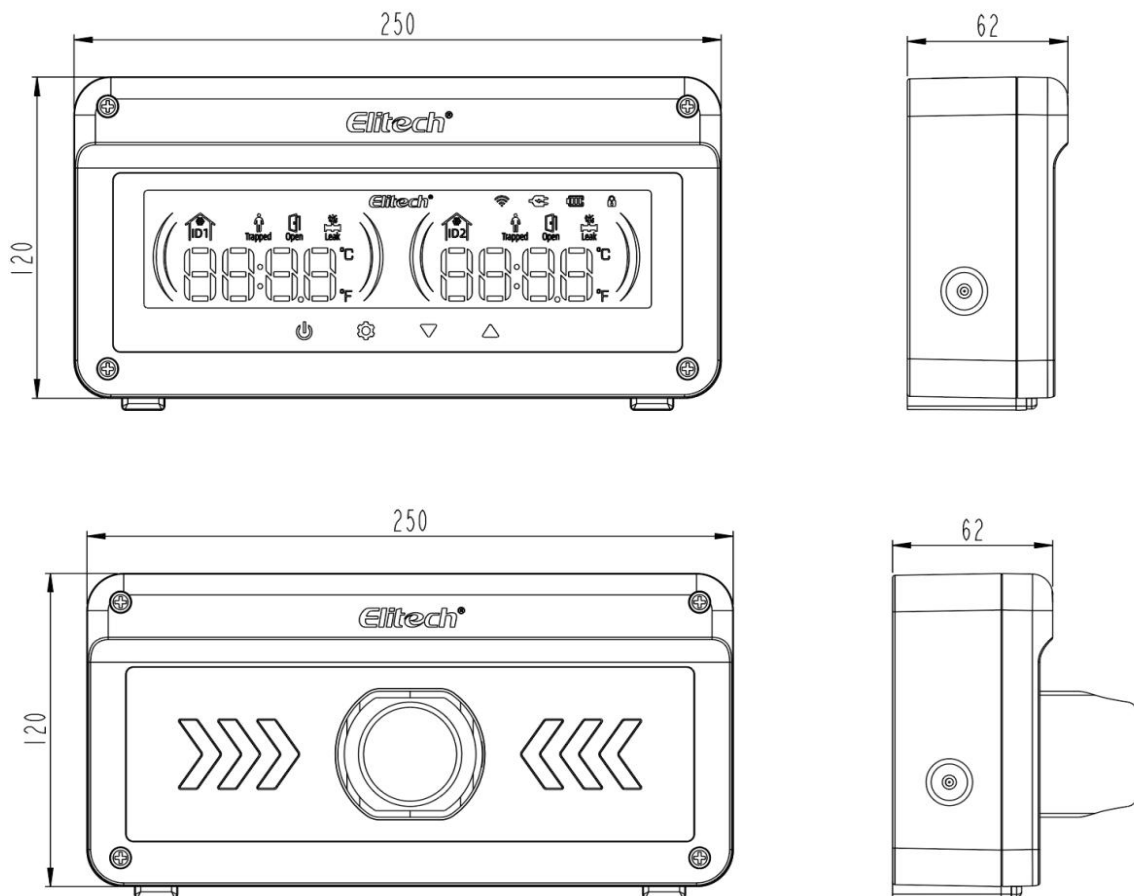

Installation steps

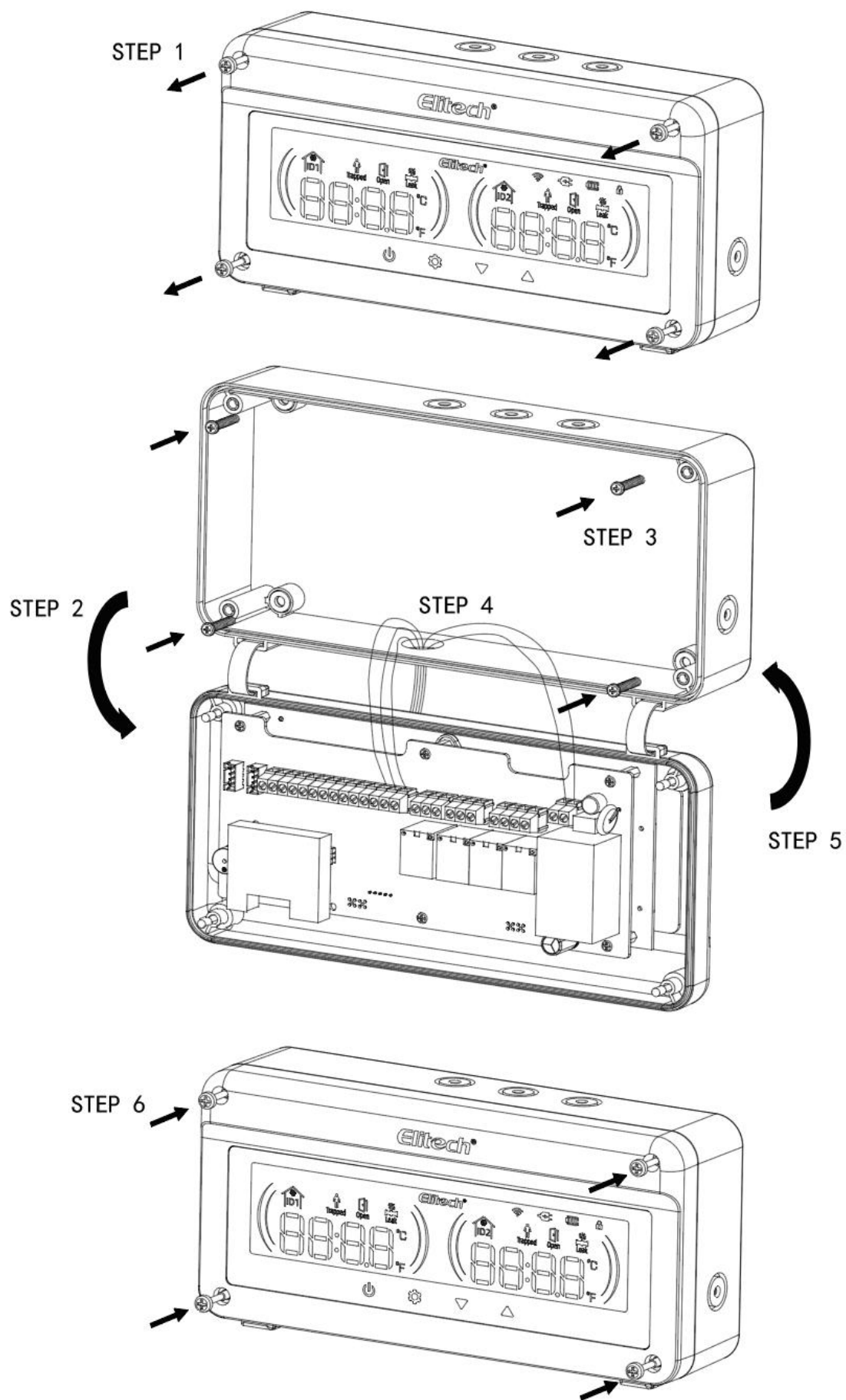

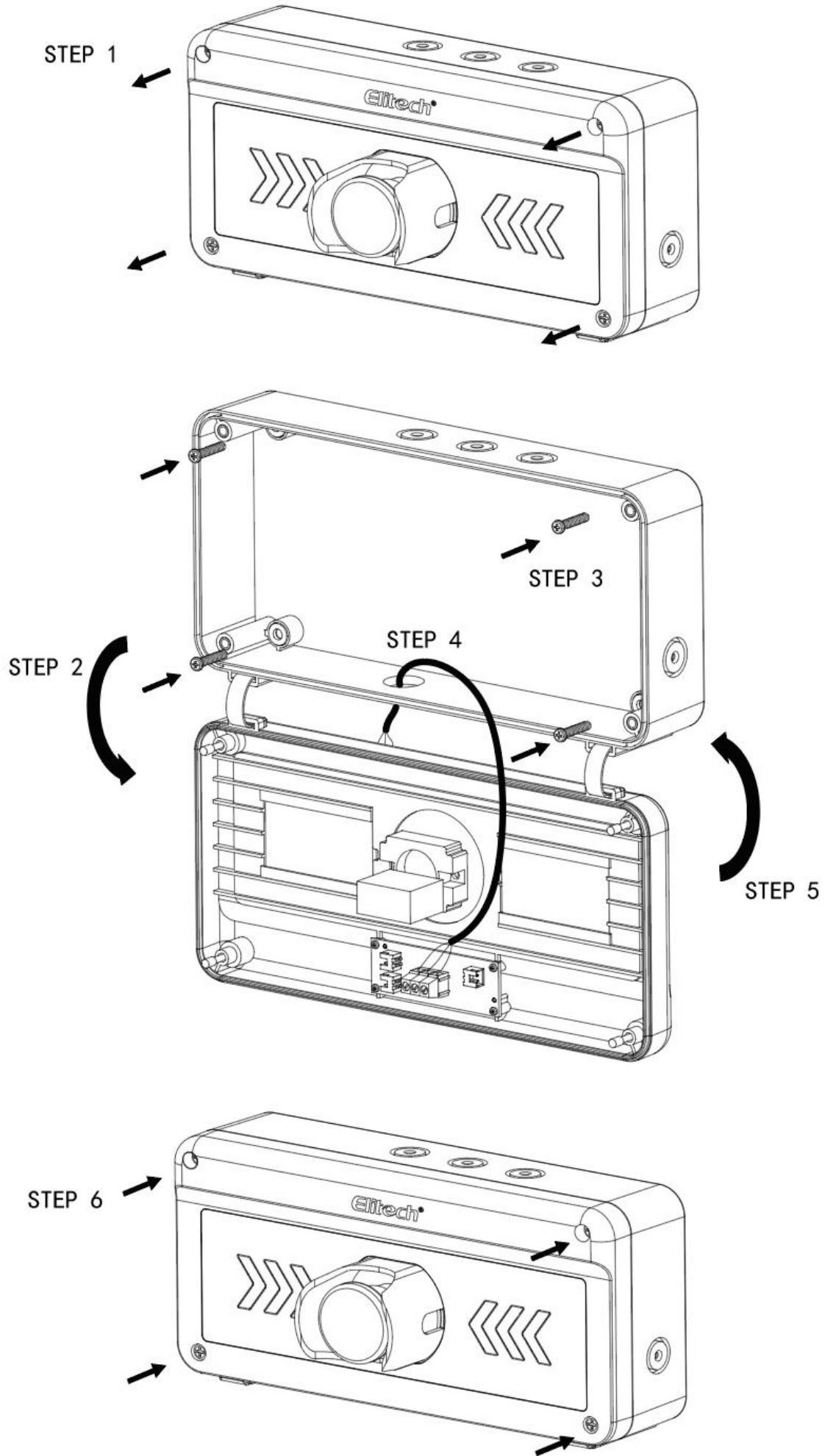

### Main functions

The cold storage alarm (EAB-80) is a dedicated alarm device for use in cold storage facilities. It features powerful functions and can alarm various types such as gas leakage, people trapped in the cold storage, door opening and closing, and excessive temperature in the cold storage. Moreover, it can communicate through our company's networked devices (such as DTU devices) and send alarm prompts synchronously on the cold cloud platform. When the power system is cut off, the cold storage alarm will continue to be powered by the internal battery for more than 10 hours.

- Support up to 20A passive output at most;
- Can monitor two groups of cold storage facilities simultaneously;
- It is equipped with a built-in WIFI networking module to achieve remote monitoring;
- Support door switch detection and refrigerant leakage detection;
- Support MODBUS-RTU communication;
- Support built-in lithium battery power supply, standby for more than 10 hours;
- Support OTA upgrade

### Technical parameters

Power supply	100~240VAC 50/60Hz
Size	250*120*62 mm
Power consumption	Less than 10W
Measurement temperature range	-49~119°C/-56~246°F
Temperature resolution	The accuracy is $\pm 1^{\circ}\text{C}$ within the range of -20 to 50°C, and $\pm 1.5^{\circ}\text{C}$ for the rest
Gas concentration resolution	1ppm
Battery capacity	3000mAh
Sensor type	NTC (10K $\Omega$ /25°C , B value :3435K)
Sensor wire length	2 meters (including the length of the probe)
Relay output	Relay1: 10A 220V(NO)/5A 220V(NC) Relay2: 20A 220V (NO)
Standby time	More than 10 hours
Storage temperature	-10°C ~ 75°C
Working environment temperature	-10°C ~ 65°C

### Operation and display panel

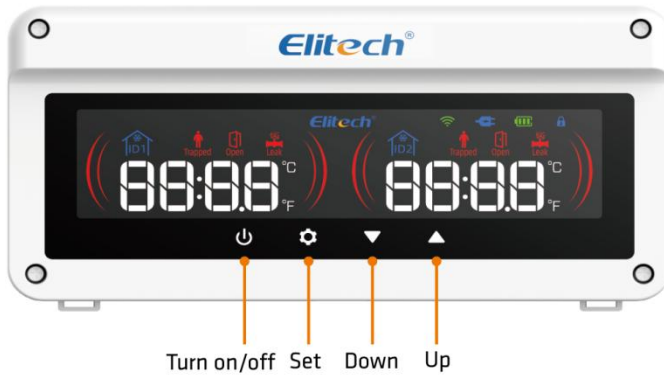

- WIFI Indicator Light

---

- Power Indicator Light

---

- Battery Indicator Light

---

- Lock Indicator Light

---

- Person In Cold Storage Indicator

---

- Door Switch Indicator Light

---

- Gas Leakage Indicator Light

---

- Cold Storage 1 Work Indicator Light

---

- Cold Storage 2 Work Indicator Light





### Display symbol description

Icon	Status	Meaning
	Off	No power supply connected
	On	power supply connected
	Off	Button in cold storage not pressed
	On	Button in cold storage pressed
	Off	Door closed
	On	Door open
	Red On	Battery level below 30%
	Green On	Battery level above 30%
	Off	No battery installed
	Off	No gas leakage or detection not enabled
	On	Gas leakage detected
	Off	No network connection
	Flash Slowly	Weak network signal
	Flash Fast	Medium network signal

	On	Strong network signal
	Off	Key can be used
	On	Key cannot be used
	On	Storage 1 in use
	Off	Storage 2 not in use
	On	Storage 2 in use
	Off	No person in cold storage (alarm)
	Flash	Person in cold storage (alarm)



**Key operation instructions**

	In normal mode, press and hold the shutdown key for 3 seconds, and the device will be turned off/on.
	In other modes, briefly press the shutdown key to return to the superior menu.
	In normal mode, press and hold the setting key for 3 seconds to enter the parameter setting mode interface.
	In the parameter setting mode interface, briefly press the setting key to enter or exit the selected parameters.
	In the parameter setting mode interface, hold down the setting key for 3 seconds, then save the parameters and exit the mode.
	In the time setting mode interface, briefly press the setting key to switch to the currently selected time position.
	When the current viewable value interface is a wifi signal, press and hold for 3 seconds to reset the wifi.
	In normal mode, press and hold the key for 3 seconds to release the lock function.



	In normal mode, press the key briefly to enter the current other searchable value interface.
	In other modes, press the key briefly to reduce the parameter value;
	In normal mode, press and hold the up key for 3 seconds without locking to enter the time setting.
	In other modes, press the up key briefly to increase the parameter value;
 + 	In normal mode, long press the up and down keys for more than 5 seconds to select factory reset or storage mode.





### Quick Operation Guide



#### » Button Unlock





When no operation is performed on the main interface for 30 seconds, the screen will display "", and button functions will be disabled. Press and hold "" for 3 seconds to unlock the buttons.

#### » System Parameter Settings

1. When the device displays the storage temperature and the interface does not show "", press and hold "" for 3 seconds to enter the system parameter settings interface.

2. If no password is set, the interface will display "A01"; if a password is set, the interface will display "PS". Then press "" to enter the password input interface, where the initial display is "000". Adjust the password value using "" or "", and press "" to confirm. If the password matches the set value, the interface will display "A01"; otherwise, it will exit the password input interface and return to the main interface.

3. After entering the system parameter interface, use "" or "" to switch between menu parameter options, and press "" to enter the specific value modification for the selected parameter.

When modifying the specific value of a parameter, use "" or "" to increase or decrease the value, and press "" or "" to return to the parameter selection interface.

4. After completing parameter modifications, press and hold "" for 3 seconds to save the parameters and exit the system parameter settings interface.

If "" is pressed or no operation is performed for over 30 seconds, the system parameter settings interface will still exit, but any modified parameters will not be saved.

Manager parameter table:

Serial Number	parameter	Parameter Description	Parameter range	Default value	MODBUS register address (hexadecimal)
Cold Storage 1 Setting					
1	A01	<b>Temperature Sensor Enable</b> (1: On, 0: Off)	0~1	1	0x0400
2	A02	<b>Temperature Sensor Calibration</b>	-12.0°C~12.0°C	0.0	0x010D
3	A03	<b>High/Low Temperature Alarm Enable</b> (1: On, 0: Off)	0~1	0	0x0401
4	A04	<b>High Temperature Alarm</b>	A05+0.1~99.0°C	20.0	0x010E
5	A05	<b>Low Temperature Alarm</b>	-49.0°C~A04-0.1	-10.0	0x010F
6	A06	<b>Alarm Hysteresis</b>	0~30.0°C	5.0	0x0110
7	A07	<b>Alarm Delay</b>	0~120min	60	0x0111
8	A08	<b>Door Open/Close Alarm Enable</b> (1: On, 0: Off)	0~1	0	0x0402
9	A09	<b>Door Default State</b> (1: Normally Open, 0: Normally Closed)	0~1	0	0x0403
10	A10	<b>Door Alarm Delay</b>	0~120min	30	0x0112
11	A11	<b>Gas Leak Detection Enable</b> (0: Off, 1: On)	0~1	0	0x0404
12	A12	<b>Gas Concentration Upper Limit</b>	1-9999ppm	5000	0x0113
13	A13	<b>Gas Concentration Alarm Threshold</b>	0~99.0%	20.0	0x0114
14	A14	<b>Gas Concentration Alarm Hysteresis</b>	0~40.0%	2.0	0x0115
15	A15	<b>Gas Alarm Recovery Enable</b> (1: Enable, 0: Disable)	0~1	1	0x0405
16	A16	<b>Number of Gas Sensors Connected</b>	1~4	1	0x0116
17	A17	<b>Gas Sensor Address</b>	1-127	1	0x0117
18	A18	<b>Gas Concentration Register Setting</b>	0-0xffff	0	0x0118
19	A19	<b>Gas Concentration Decimal Places Setting</b>	0-2	0	0x0119
20	A20	<b>Gas Sensor Baud Rate Setting</b>	0:2400; 1:9600	1	0x0406
21	A21	<b>Gas Sensor Stop Bit Setting</b>	0: 1bit; 1: 2bit	0	0x0407
22	A22	<b>Person Trapped Alarm Recovery Enable</b> (1: Enable, 0: Disable)	0~1	1	0x0408
23	A23	<b>Alarm Relay 1 Trigger Condition</b> (1: Person Trapped Alarm / Gas Leak Alarm; 2: Person Trapped Alarm / Gas Leak Alarm / Door Alarm; 3: Person Trapped Alarm / Gas Leak Alarm / Temperature Alarm; 4: Person Trapped Alarm / Gas Leak Alarm / Door Alarm / Temperature Alarm)	1~4	1	0x0409

24	A24	<b>Alarm Relay 2 Function</b> ( 0: Off; 1: Person Trapped Alarm Auxiliary Output; 2: Gas Leak Alarm Auxiliary Output; 3: Door Alarm Auxiliary Output; 4: Temperature Alarm Auxiliary Output )	0~4	1	0x040a
25	A25	<b>Alarm Relay 2 Output Delay Time</b>	0-7200s	0	0x011A
Common Parameters					
26	P01	<b>Buzzer Alarm Enable</b> (1: On, 0: Off)	0~1	1	0x040b
27	P02	<b>Temperature Unit</b> (0: Fahrenheit, 1: Celsius)	0~1	1	0x040c
28	P03	<b>Communication Address (MODBUS)</b>	1~127	1	0x011B
29	P04	<b>System Password</b>	0~999	0	0x011C
30	P05	<b>Network Function Enable</b> (1: On, 0: Off)	0~1	1	0x040d
31	ID	<b>Dual Control Enable</b> ( 1: On, 0: Off)	0~1	0	0x040e
Cold Storage 2 Setting					
32	B01	<b>Temperature Sensor Enable</b> (1: On, 0: Off)	0~1	1	0x040f
33	B02	<b>Temperature Sensor Calibration</b>	-12.0°C~12.0°C	0.0	0x011D
34	B03	<b>High/Low Temperature Alarm Enable</b> (1: On, 0: Off)	0~1	0	0x0410
35	B04	<b>High Temperature Alarm</b>	B05+0.1~99.0°C	20.0	0x011E
36	B05	<b>Low Temperature Alarm</b>	-49.0°C~B04-0.1	-10.0	0x011F
37	B06	<b>Alarm Hysteresis</b>	0~30.0°C	5.0	0x0120
38	B07	<b>Alarm Delay</b>	0~120min	60	0x0121
39	B08	<b>Door Open/Close Alarm Enable</b> (1: On, 0: Off)	0~1	0	0x0411
40	B09	<b>Door Default State</b> (1: Normally Open, 0: Normally Closed)	0~1	0	0x0412
41	B10	<b>Door Alarm Delay</b>	0~120min	30	0x0122
42	B11	<b>Gas Leak Detection Enable</b> (0: Off, 1: On)	0~1	0	0x0413
43	B12	<b>Gas Concentration Upper Limit</b>	1-9999ppm	5000	0x0123
44	B13	<b>Gas Concentration Alarm Threshold</b>	0~99.0%	20.0	0x0124
45	B14	<b>Gas Concentration Alarm Hysteresis</b>	0~40.0%	2.0	0x0125
46	B15	<b>Gas Alarm Recovery Enable</b> (1: Enable, 0: Disable)	0~1	0	0x0414
47	B16	<b>Number of Gas Sensors Connected</b>	1~4	1	0x0126
48	B17	<b>Gas Sensor Address</b>	1-127	1	0x0127
49	B18	<b>Gas Concentration Register Setting</b>	0+0xffff	0	0x0128
50	B19	<b>Gas Concentration Decimal Places Setting</b>	0-2	0	0x0129
51	B20	<b>Gas Sensor Baud Rate Setting</b>	0:2400;	1	0x0415

			1:9600		
52	B21	<b>Gas Sensor Stop Bit Setting</b>	0: 1bit; 1: 2bit	0	0x0416
53	B22	<b>Person Trapped Alarm Recovery Enable</b> (1: Enable, 0: Disable)	0~1	1	0x0417
54	B23	<b>Alarm Relay 1 Trigger Condition</b> ( 1: Person Trapped Alarm / Gas Leak Alarm; 2: Person Trapped Alarm / Gas Leak Alarm / Door Alarm; 3: Person Trapped Alarm / Gas Leak Alarm / Temperature Alarm; 4: Person Trapped Alarm / Gas Leak Alarm / Door Alarm / Temperature Alarm )	1~4	1	0x0418
55	B24	<b>Alarm Relay 2 Function</b> ( 0: Off; 1: Person Trapped Alarm Auxiliary Output; 2: Gas Leak Alarm Auxiliary Output; 3: Door Alarm Auxiliary Output; 4: Temperature Alarm Auxiliary Output )	0~4	1	0x0419
56	B25	<b>Alarm Relay 2 Output Delay Time</b>	0-7200s	0	0x012A

### Additional Data Viewing

When the device is unlocked, briefly press "▽" to enter the additional data viewing interface. Use "△" or "▽" to switch between different data types. The data is displayed in the following order:

- ①Date (Year-Month-Day)②Time (Hour-Minute-Second)③Wi-Fi Signal ④Cold Storage 1 – Gas Concentration 1 ⑤ Cold Storage 1 – Gas Concentration 2 ⑥Cold Storage 1 – Gas Concentration 3 ⑦Cold Storage 1 – Gas Concentration 4 ⑧Cold Storage 2 – Gas Concentration 1 ⑨Cold Storage 2 – Gas Concentration 2 ⑩Cold Storage 2 – Gas Concentration 3 ⑪Cold Storage 2 – Gas Concentration 4 ⑫SOC ⑬OTA Update Progress

### Battery Power Instructions

When the device is powered on, it will monitor the battery level in real time. When the battery level is lower than 100%, it will automatically charge until the battery is fully charged.

When the device is powered only by the battery, you can long-press "△" and "▽" for more than 5 seconds to enter the mode selection. When the interface displays "SOC OFF", then click "⚙️", and the device will enter the storage mode and disconnect the battery power supply.

Note: When the device is powered off from the battery, it cannot be powered by the battery again. It needs to be re-connected to the mains power supply.

**>> Power On/Off Function:**

When the device is in the unlocked state, long-press " " for more than 3 seconds to enter the shutdown state. The controller output will be disconnected, and the window will display "off" .



When in the shutdown state, long-press " " for more than 3 seconds to enter the normal operation state.

When in the shutdown state, the relay output will be disconnected, and the alarm will be canceled.



**>> Clock Calibration Function:**



When the device is in the unlocked state, long-press " " for more than 3 seconds to enter the time setting interface.

First, the "year" position will blink. Press " " or " " to adjust the year, and press " " to save the year.

After the year is saved, the "month" position will blink. Press " " or " " to adjust the month, and press " " to save the month.

After the month is saved, the "day" position will blink. Press " " or " " to adjust the day, and press " " to save the day.

After the day is saved, the "hour" position will blink. Press " " or " " to adjust the hour, and press " " to save the hour.

After the hour is saved, the "minute" position will blink. Press " " or " " to adjust the minute, and press " " to save the minute.

After saving the minute, the time setting interface will exit and display the main interface.

If " " is pressed in the time setting interface or there is no operation for more than 30 seconds, the interface will exit, but the time will not be saved.

Note: When the parameter A01 or B01 is set to 0, the current time (hour and minute) will be displayed on the main interface.

**Alarm Output Control and Alarm Code Instructions**

In normal operation, the buzzer will alarm in the following cases. Press any key to cancel the buzzer alarm sound:

1. Cold Storage 1 Temperature Sensor Alarm E1

When A01=1 and the temperature sensor of Cold Storage 1 is short-circuited or open-circuited, the interface will display alarm E1.

2. Cold Storage 1 Temperature Sensor High-Temperature Alarm E2

When A01=1 and A03=1, if the temperature detected by the Cold Storage 1 temperature sensor is  $\geq A04$ , timing starts. If the temperature remains  $\geq A04$  after lasting for A07 time, alarm E2 will be triggered until the detected temperature of the Cold Storage 1 temperature sensor  $\leq A04-A06$ .

3. Cold Storage 1 Temperature Sensor Low-Temperature Alarm E3

When A01=1 and A03=1, if the temperature detected by the Cold Storage 1 temperature sensor is  $\leq A05$ , timing starts. If the temperature remains  $\leq A05$  after lasting for A07 time, alarm E3 will be triggered until the detected temperature of the Cold Storage 1 temperature sensor  $\geq A05+A06$ .

4. Cold Storage 1 Door Switch Alarm

When A08=1 and the door switch status is opposite to the default status of A09, timing starts. If the door switch status remains opposite to the default status of A09 after lasting for A10 time, the icon will stay on until the status matches the default status of A09.

5. Person Trapped in Cold Storage 1 Alarm

When the alarm button of Cold Storage 1 is pressed, the indicator lights on both sides of the button will start flashing, and the cold storage alarm will activate with the icon staying on and the indicator lights flashing.

If A22=1, after the button is reset, the alarm will continue; press any button to cancel the alarm.

If A22=0, the alarm will be canceled after the button is reset.

#### 6. Cold Storage 1 Gas Leakage Alarm

When  $A11=1$  and the gas detection concentration in Cold Storage 1 is  $\geq A12$ , the icon will stay on until the detected concentration  $\leq A12*(A13-A14)$ , and the alarm will be canceled.

The following alarms are allowed only when  $P06=1$ :

#### 7. Cold Storage 2 Temperature Sensor Alarm E4

When  $B01=1$  and the temperature sensor of Cold Storage 2 is short-circuited or open-circuited, the interface will display alarm E4.

#### 8. Cold Storage 2 Temperature Sensor High-Temperature Alarm E5

When  $B01=1$  and  $B03=1$ , if the temperature detected by the Cold Storage 2 temperature sensor is  $\geq B04$ , timing starts. If the temperature remains  $\geq B04$  after lasting for  $B07$  time, alarm E5 will be triggered until the detected temperature of the Cold Storage 2 temperature sensor  $\leq B04-B06$ .

#### 9. Cold Storage 2 Temperature Sensor Low-Temperature Alarm E6

When  $B01=1$  and  $B03=1$ , if the temperature detected by the Cold Storage 2 temperature sensor is  $\leq B05$ , timing starts. If the temperature remains  $\leq B05$  after lasting for  $B07$  time, alarm E6 will be triggered until the detected temperature of the Cold Storage 2 temperature sensor  $\geq B05+B06$ .

#### 10. Cold Storage 2 Door Switch Alarm

When  $B08=1$  and the door switch status is opposite to the default status of  $B09$ , timing starts. If the door switch status remains opposite to the default status of  $B09$  after lasting for  $B10$  time, the icon will stay on until the status matches the default status of  $B09$ .

#### 11. Person Trapped in Cold Storage 2 Alarm

When the alarm button of Cold Storage 2 is pressed, the indicator lights on both sides of the button will start flashing, and the cold storage alarm will activate with the icon staying on and the indicator lights flashing.

If  $B22=1$ , after the button is reset, the alarm will continue; press any button to cancel the alarm.

If  $B22=0$ , the alarm will be canceled after the button is reset.

#### 12. Cold Storage 2 Gas Leakage Alarm

When  $B11=1$  and the gas detection concentration in Cold Storage 2 is  $\geq B12$ , the icon will stay on until the detected concentration  $\leq B12*(B13-B14)$ , and the alarm will be canceled.

#### Relay Output Control

When the cold storage alarm meets any alarm signal in parameters  $A23$  or  $B23$ , the corresponding No.1 relay will output an alarm. For other alarm signals, only the alarm code is displayed without relay output.

When the cold storage alarm meets any alarm signal in parameters  $A24$  or  $B24$ , if the signal lasts for  $A25$  or  $B25$  time, the corresponding No.2 relay will output an alarm. For other alarm signals, only the alarm code is displayed without relay output.

### Gas Leakage Alarm Instructions

The cold storage alarm supports various gas sensors with MODBUS functions (such as  $\text{CO}_2$ ,  $\text{R290}$ ,  $\text{NH}_3$ ). The default communication baud rate is 9600bps, with 8-bit data length, 1 stop bit, and no parity bit. The port can support up to 4 gas sensors for gas detection, and the number of connected gas sensors is adapted by setting  $A16$ .

Take a Gas Sensor Connected to Cold Storage 1 as an Example to Explain Gas Leakage Detection:

**Parameter Enablement:** When enabling parameter  $A11$ , complete the adaptation settings for the address code and register of the gas sensor by setting  $A17$  and  $A18$  to ensure normal communication with the gas sensor.

**Concentration Comparison:** Compare the incoming concentration value with the set concentration leakage alarm threshold to determine whether a leakage occurs.

**Alarm Trigger:** If a leakage is detected, the alarm will be activated.

Reading the Concentration of a Certain Gas:

Device Address	Function Code	High Byte of Start Register Address	Low Byte of Start Register Address	High Byte of Number of Registers to Read	Low Byte of Number of Registers to Read	CRC Check (2 bytes)
A17	0x03	A18		0x00	0x01	CRC

Return from the Gas Sensor:

Device Address	Function Code	Number of Return Data Bytes	High Byte of Register 1 Data	Low Byte of Register 1 Data	CRC Check (2 bytes)
A17	0x03	0x02	xx	yy	CRC

Explanation: The returned data “xxyy” represents the concentration. If the resolution is 0.1ppm, for example: if xx = 0x00 and yy = 0x14, then the concentration of R290 is 0x0014, which is converted to decimal as 2.0ppm.

Notes:

The concentration reading display resolution of the cold storage alarm is 1ppm.

If A16 is set to be greater than 1, the cold storage alarm will increase the device addresses of the other gas sensors by 1, 2, or 3 (depending on the value of A16). For example, if A16 is set to 3, for the 3 connected gas sensors, the device address of sensor 1 is A17, the device address of sensor 2 is A17 + 1, and the device address of sensor 3 is A17 + 2.

### MODBUS-RTU RS485

This system adopts the MODBUS-RTU communication slave mode, with a baud rate of 9600, no parity, 8 data bits, and 1 stop bit. It supports MODBUS-RTU commands 03 (read holding registers, with a maximum of 10 registers readable) and 06 (write a single register). The addresses of parameter registers (allowing reading and writing) can be found in the parameter table above, and the addresses of status registers (read-only) can be found in the following table.

Register Address	Description	Bit Definition			
0x0200	Relay Output Status	MSByte	Bit7(MSB)	Reserved	
			Bit6	Reserved	
			Bit5	Reserved	
			Bit4	Reserved	
			Bit3	Reserved	
			Bit2	Reserved	
			Bit1	Reserved	
		Bit0	Reserved		
		LSByte	Bit7(MSB)	Reserved	
			Bit6	Reserved	
			Bit5	Reserved	
			Bit4	Reserved	
			Bit3	Relay 2 of Cold storage 2	0: Disabled; 1: Enabled
			Bit2	Relay 1 of Cold storage 2	0: Disabled; 1: Enabled
Bit1	Relay 2 of Cold storage 1		0: Disabled; 1: Enabled		
Bit0	Relay 1 of Cold storage 1	0: Disabled; 1: Enabled			
0x0300	Alarm Status	MSByte	Bit7(MSB)	Reserved	
			Bit6	Reserved	
			Bit5	Reserved	
			Bit4	Parameter storage error alarm	0: No alarm; 1: Alarm

		Bit3	gas leakage in cold storage 2 alarm	0: No alarm; 1: Alarm
		Bit2	Person in cold storage 2 alarm	0: No alarm; 1: Alarm
		Bit1	door switch in cold storage 2 alarm	0: No alarm; 1: Alarm
		Bit0	low - temperature in cold storage 2 alarm	0: No alarm; 1: Alarm
	LSByte	Bit7(MSB)	high - temperature in cold storage 2 alarm	0: No alarm; 1: Alarm
		Bit6	sensor fault in cold storage 2 alarm	0: No alarm; 1: Alarm
		Bit5	gas leakage in cold storage 1 alarm	0: No alarm; 1: Alarm
		Bit4	Person in cold storage 1 alarm	0: No alarm; 1: Alarm
		Bit3	door switch in cold storage 1 alarm	0: No alarm; 1: Alarm
		Bit2	low - temperature in cold storage 1 alarm	0: No alarm; 1: Alarm
		Bit1	high - temperature in cold storage 1 alarm	0: No alarm; 1: Alarm
		Bit0	sensor fault in cold storage 1 alarm	0: No alarm; 1: Alarm

Restore factory parameter Settings

On the normal display interface, long press "▲" and "▼" for more than 5 seconds, and "SOC OFF" will appear. Then click "▲" and "▼" to find "FAC", and then click "⚙️" to show "YES", and the parameters will be restored to factory Settings. When waiting for the normal temperature to be displayed, the power must be cut off and the product restarted to ensure its normal operation.

**Networking function**

In the unlocked state of the device, short press "▼" to enter the remaining data viewing interface, press "▲" or "▼" to find the WIFI parameter item, then long press "⚙️" for 3 seconds, "WIFI RST" will appear, and the cold storage alarm will enter the distribution network mode. Then open the "Elitech iCold" APP with your phone, turn on Bluetooth, and connect to WiFi. After logging in with your account and password, click the "+" in the upper right corner of the main interface, scan the device's UID QR code, and then follow the prompts to add the device.

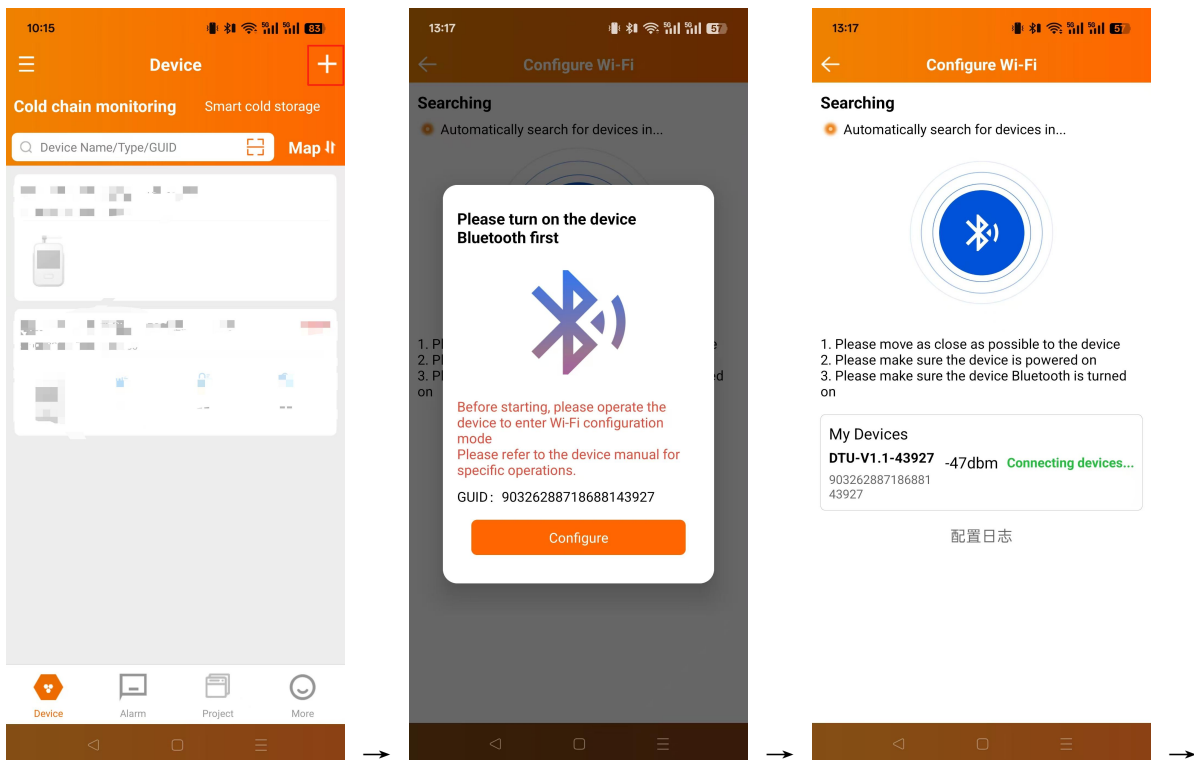

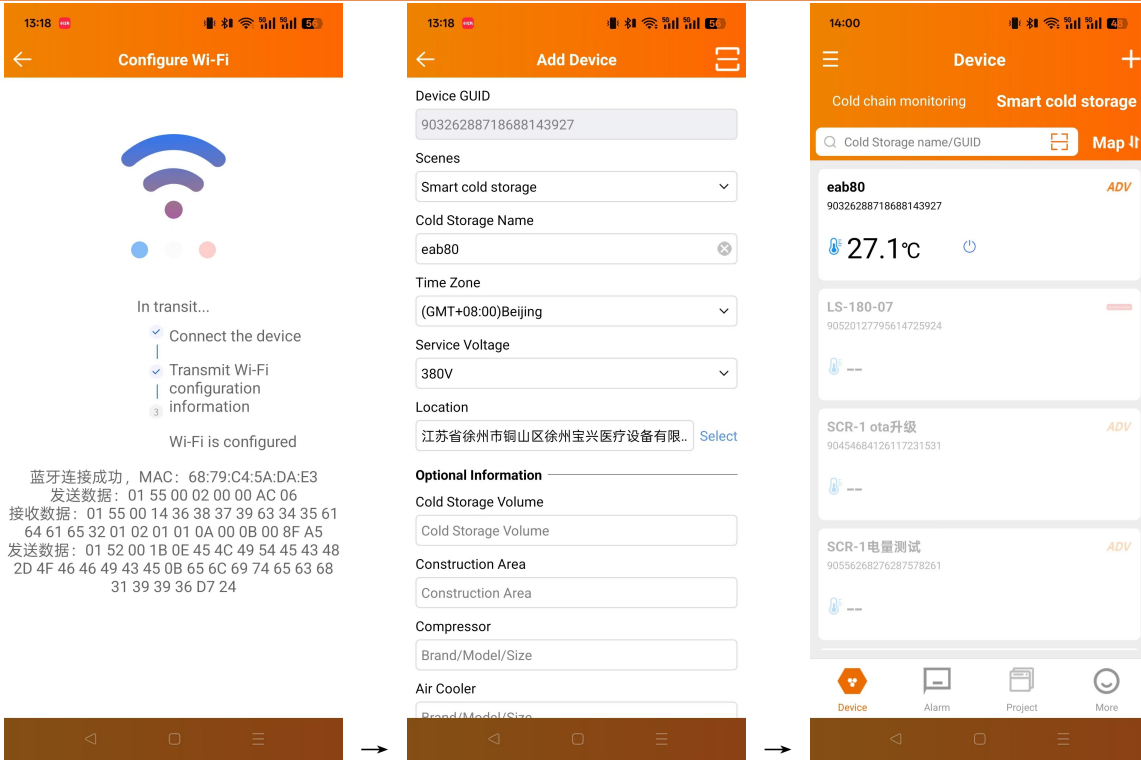

## Wiring diagram

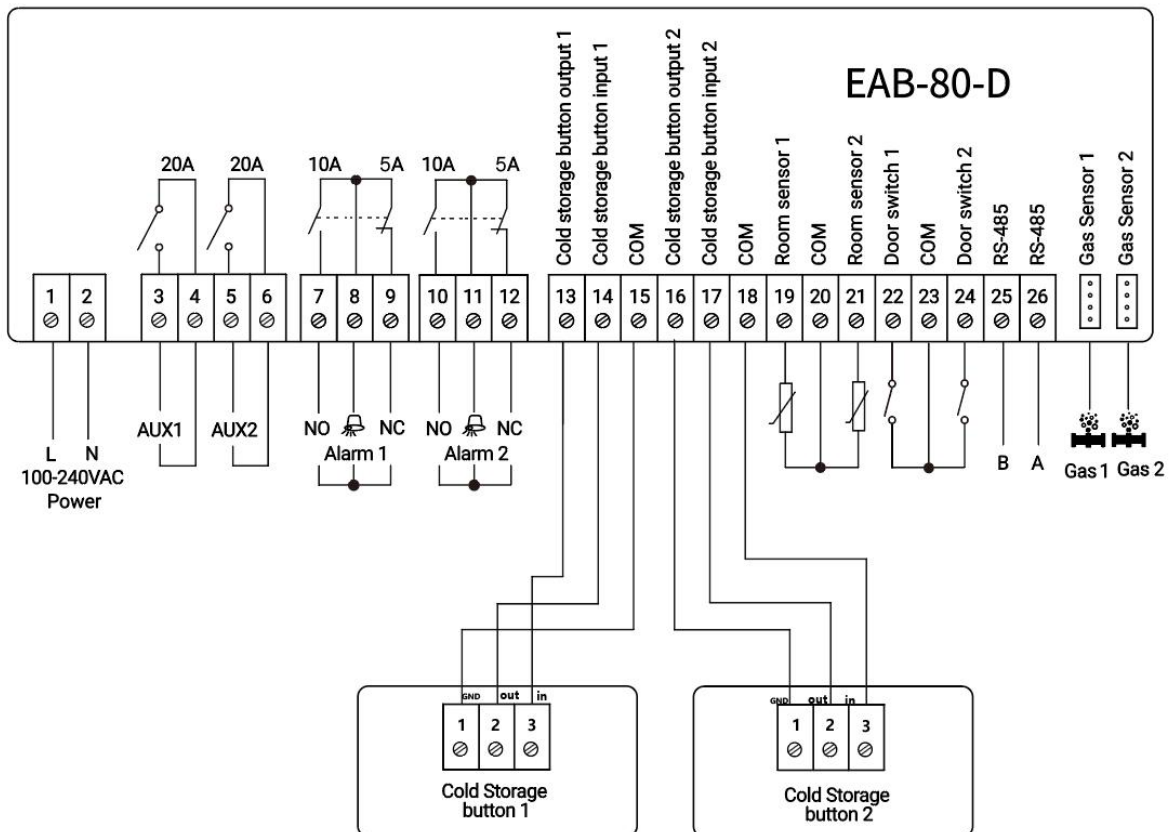

Appendix: Character Set

